

Before the United States House Committee on the Judiciary
Subcommittee on Courts, Intellectual Property, and the Internet

118th Congress

Hearing, Is There a Right to Repair?

July 18, 2023

Testimony and Statement of Aaron Perzanowski
Thomas W. Lacchia Professor of Law
University of Michigan Law School

Chairman Issa, Ranking Member Johnson, and Members of the Subcommittee:

Thank you for the opportunity to offer testimony addressing the relationship between intellectual property (IP) law and restrictions on repair. For the last fifteen years, I have been teaching, writing, and speaking about intellectual property law. The primary focus of my academic research has been the erosion of consumers' personal property rights in the digital economy.¹ Over the last decade, the right to repair has emerged as a central challenge to the notion that we control the devices we buy. Instead, consumers, farmers, and small businesses across the country find that manufacturers exert post-sale control over these devices, often in ways that frustrate repair. My most recent book, *The Right to Repair*, explores these issues at length, with a particular focus on the ways in which IP law can either exacerbate or alleviate the difficulties facing owners who want to repair their devices.² Despite efforts by manufacturers to stymie repair, the right to repair is broadly consistent with nearly two centuries of IP law.

In part because of this long history within our legal system, consumers have strong expectations when it comes to their right to repair the devices they own. My own research, which is consistent with survey data and state-level referenda on repair, shows that more than 80% of consumers believe they should be able to repair their devices themselves or rely on the repair shop of their choice.³ Indeed, consumers who turn to independent providers are more satisfied with their repair services than those who rely on manufacturers for repairs.⁴ Not surprisingly, right to repair legislation is overwhelmingly popular, and support for this policy is consistently

¹ Aaron Perzanowski & Jason Schultz, *The End of Ownership* (MIT Press 2016).

² Aaron Perzanowski, *The Right to Repair: Reclaiming the Things We Own* (Cambridge University Press 2022).

³ Aaron Perzanowski, *Consumer Perceptions of the Right to Repair*, 96 *Indiana Law Journal* 361 (2021).

⁴ *Should You Repair or Replace that Product? How to Save Money on Appliances, Electronics, and Lawn and Yard Gear*, *Consumer Reports* (Jan. 2014), www.consumerreports.org/cro/magazine/2014/02/repair-or-replace/index.htm.

high across demographic and party lines.⁵ As a letter from 28 State Attorneys General recently noted, “The Right-to-Repair is a bipartisan issue that impacts every consumer, household, and farm in a time of increasing inflation.”⁶

As a result, state legislatures across the country have taken up right to repair legislation. Thirty states have introduced such bills this year alone.⁷ Colorado, Massachusetts, Minnesota, and New York have enacted laws recognizing consumers’ right to repair in recent years.⁸ Despite those efforts, repair restrictions call out for a federal solution. Markets for vehicles, home appliances, and electronics are national in scope. While states are empowered to enact laws that safeguard the interests of their citizens, federal legislation promises consistency and uniformity that would benefit consumers, manufacturers, and repair providers. Moreover, since some repair restrictions are the byproduct of aggressive assertions of federal IP rights, Congress can provide much needed leadership by crafting sensible solutions that protect the rights of consumers while recognizing the need for balanced IP protections.

The History of Repair

The practice of repair is as old as humanity. Our Paleolithic ancestors repaired hand axes and other primitive tools.⁹ As our technologies grew more complex, so did our methods of repair. From the Bronze Age through the Renaissance, whatever technology we dreamed up, new methods of repair followed just a step behind. Eventually, industrialization and the introduction of interchangeable parts made repair easier and more reliable than ever before.

From a modern perspective, it’s difficult to imagine the breakthrough interchangeable parts represented. In 1785, Thomas Jefferson—then United States Minister to France—wrote about the pioneering work of gun-smith Honoré Blanc, which he witnessed firsthand: “He presented me the parts of fifty locks taken to pieces, and arranged in compartments. I put several together myself, taking pieces at hazard as they came to hand, and they fitted in the most perfect manner.”¹⁰ Sixteen years later, President-elect Jefferson, watched a similar exhibition by Eli Whitney, who used a screwdriver to attach ten different locks to a single musket. He then disassembled the locks and put them back together, mixing and matching the parts. This interchangeability allowed for quick and reliable battlefield repairs.

⁵ *Right to Repair: A Nationally Representative Multi-Mode Survey*, Consumer Reports, https://article.images.consumerreports.org/prod/content/dam/surveys/Consumer_Reports_Right_to_Repair_Survey_2021.

⁶ Letter from State Attorneys General to Representative McMorris Rodgers, Representative Pallone, Senator Cantwell and Senator Cruz, [https://oag.ca.gov/system/files/attachments/press-docs/3.24.2023 Right to Repair Ltr. to Congress FINAL.pdf](https://oag.ca.gov/system/files/attachments/press-docs/3.24.2023%20Right%20to%20Repair%20Ltr.%20to%20Congress%20FINAL.pdf)

⁷ *Pennsylvania Becomes 30th State to Put Forward Right to Repair Legislation*, U.S. PIRG, <https://pirg.org/updates/pennsylvania-becomes-30th-state-to-put-forward-right-to-repair-legislation/>

⁸ Id.

⁹ Ron Shimelmitz, Michael Bisson, Mina Weinstein-Evron & Steven L. Kuhn, *Handaxe Manufacture and Re-Sharpening throughout the Lower Paleolithic Sequence of Tabun Cave*, 428 *Quaternary International* 118 (2017).

¹⁰ Giles Slade, *Made to Break: Technology and Obsolescence in America* (2006).

In time, those same principles were applied to mass produced consumer goods. In 1908, Henry Leland, the founder of both Cadillac and Lincoln, updated Blanc's demonstration. Three Cadillacs were disassembled, their parts intermingled, and then reassembled and driven some 500 miles without incident.¹¹ That same year, Henry Ford began production of the Model T. Not only did Ford embrace interchangeability as a production strategy, but the company understood that widely available and easily replaced parts made its cars more valuable. Every Ford included a toolkit and a straightforward repair manual that walked owners through basic fixes.¹²

Over the course of the twentieth century, assembly lines became so efficient that the calculus around repair and durability shifted. Modern manufacturing meant plummeting assembly times and labor costs. Companies quickly came to appreciate that product durability wasn't always in their economic self-interest. Demand needed to keep up with supply, so manufacturers found ways to induce consumption and discourage repair. As early as the 1920s, firms were exploring the strategies that would eventually become known as "planned obsolescence."

Beginning in 1924, the Phoebus group—spearheaded by General Electric and comprising the leading lightbulb manufacturers of France, Germany, Hungary, Japan, the Netherlands, and the United Kingdom—set out to reduce the lifespan of the world's lightbulbs.¹³ Over the course of just eight years, the average operating time of bulbs dropped from nearly 2,000 hours to a mere 1,200. From its base in Geneva, Phoebus systematically evaluated the bulbs produced by its members, fining those whose products exceeded the agreed-upon lifespan limits. Around the same time, as revealed in an internal memo uncovered by the Department of Justice, GE set out to reduce the life of its flashlight bulbs by two-thirds, a move it expected to increase sales by 60 percent.¹⁴

In the post-World War II era, manufacturers devised techniques to discourage repair of consumer goods. As detailed by Vance Packard, they included steam irons that "could be repaired only by breaking [them] apart and drilling out the screws," toasters "so riveted together" that they required almost an hour just to disassemble, and appliances that had to be fully dismantled just to swap out a 10-cent part.¹⁵ By the 1950s, some were openly endorsing "death dating," the practice of designing products to fail after a short period of use.¹⁶ Packard also described efforts to tightly control information about repair. Both consumers and independent repair providers were frustrated by appliance makers' refusals to share service manuals. Instead, as one consumer wrote,

¹¹ Office of Technology Assessment, *Global Standards: Building Blocks for the Future* (1992); Harold C. Livesay, *American Made: Shaping the American Economy* (2016).

¹² James P. Womack, Daniel T. Jones & Daniel Roos, *The Machine that Changed the World* (1990); Royce Peterson, *The 1911 Model T Ford Tool Kit, Model T Ford Fix*, <https://modeltfordfix.com/the-1911-model-t-ford-tool-kit/>.

¹³ Markus Krajewski, *The Great Lightbulb Conspiracy*, IEEE Spectrum, <https://spectrum.ieee.org/tech-history/dawn-of-electronics/the-great-lightbulb-conspiracy>.

¹⁴ Letter from L.C. Porter to M.I. Sloan, Nov. 1, 1932, U.S.v.G.E. Civil Action No. 1364, 82 F. Supp. 753 Ex. 1860-G.

¹⁵ Vance Packard, *The Waste Makers* (1960).

¹⁶ Id.

those documents were “censored as if they contained obscene material.”¹⁷ These early techniques were precursors to the more sophisticated strategies we see firms deploy today.

Current Strategies that Frustrate Repair

Today, manufacturers employ a number of strategies that restrict repair, ranging from hardware and software design to restrictions on access to secondary markets. Taken together these are powerful tools that frustrate owners who want to repair the devices they own.

Hardware design is perhaps the most obvious means by which manufacturers’ decisions can limit repair. Wireless headphones that are glued and soldered together, laptops secured with exotic screws, and washing machines that require full disassembly to replace simple ball bearings are all examples of the ways in which hardware design makes repair less convenient, more expensive, and sometimes impossible.

Modern devices from cars to home appliances also incorporate software code, network connectivity, and data-generating sensors that offer manufacturers new opportunities to shape, restrict, and interfere with consumers’ control over the products they own.¹⁸ If the functionality of a device depends on software, manufacturers can use that code to impose any number of restrictions on whether, how, and by whom that functionality can be restored. Likewise, access to performance and diagnostic data generated by a device is often necessary for repairs. But when that data is communicated through channels accessible only by the manufacturer, repair becomes more difficult, if not impossible, for independent providers. These digital tethers enable a degree of control over post-sale consumer behavior, including repair, that the law has traditionally not countenanced. This trend represents a major shift in the relationship between consumers and the devices they own.

Software can be used to detect third-party repairs and disable consumers’ devices. For example, thousands of iPhone owners were in 2016 shocked when their devices would not start up, and their contacts, photos, and other data were inaccessible.¹⁹ Phones that had been repaired by third parties and worked normally for weeks or even months were suddenly “bricked” after an Apple software update that detected a replacement connector between the device’s home button and its Touch ID sensor. When such a connector was found, the software instructed the phone to stop working altogether. After a public backlash and a class-action lawsuit, Apple eventually restored the functionality of affected iPhones. A year later, another Apple software update secretly slowed down the processors of phones with older batteries.²⁰ Once the scheme was

¹⁷ Id.

¹⁸ Chris Jay Hoofnagle, Aniket Kesari & Aaron Perzanowski, *The Tethered Economy*, 87 *Geo. Wash. L. Rev.* 783 (2019).

¹⁹ Miles Brignall, “Error 53” Fury Mounts as Apple Software Update Threatens to Kill Your iPhone 6, *The Guardian* (Feb. 5, 2016), www.theguardian.com/money/2016/feb/05/error-53-apple-iphone-software-update-handset-worthless-third-party-repair.

²⁰ Adi Robertson, *Apple Agrees to \$500 Million Settlement for Throttling Older iPhones*, *Verge* (Mar. 2, 2020), www.theverge.com/2020/3/2/21161271/apple-settlement-500-million-throttling-battery-gate-class-action-lawsuit.

discovered, Apple offered discounted battery replacements—a decision that CEO Tim Cook later blamed for flagging iPhone sales.²¹

Troublingly, we see software being deployed to essentially undo the very idea of interchangeable parts. Microsoft and Sony both pair the optical drives in their video game consoles to the devices' motherboards. As a result, if a consumers' optical drive fails, they can't replace it with an identical part.²² Similarly, John Deere tractors won't recognize properly-installed genuine replacement parts until they have been initialized, at considerable expense to farmers, by an authorized Deere technician. Hospitals contend with similar software restrictions when trained medical technicians attempt to repair ventilators and other crucial equipment.

Other devices, like Epson printers are programmed to fail even in the absence of any actual problem with the device.²³ Some printers collect excess ink in a pad or sponge. Rather than allowing owners to replace those pads, which only cost a few dollars, Epson estimates the number of pages the device can print before saturation. Once it reaches that fixed number of pages, the printer will display a message stating that it has “reached the end of its service life” and simply refuse to operate.

Aside from hardware and software design, a number of additional strategies can limit the availability and feasibility of repair:

- Withholding replacement parts from consumers and independent repair shops;²⁴
- Authorized repair networks that restrict which repairs providers are permitted to perform;²⁵
- Agreements between manufacturers and retailers like Amazon that restrict the availability of refurbished devices;²⁶ and
- Refusals to allow advertisements from independent repair providers, like the one imposed by Google.²⁷

²¹ Jason Koebler, *Tim Cook to Investors: People Bought Fewer New iPhones Because They Repaired Their Old Ones*, Vice (Jan. 2, 2019), www.vice.com/en_us/article/zmd9a5/tim-cook-to-investors-people-bought-fewer-new-iphones-because-they-repaired-their-old-ones.

²² Kyle Wiens, *Copyright Law Is Bricking Your Game Console. Time to Fix That*, Wired (Dec. 11, 2020), www.wired.com/story/copyright-law-is-bricking-your-game-console-time-to-fix-that.

²³ Sharon Harding, *Epson's Bricked Printers Highlight the Industry's Repairability Problem*, Ars Technica (Aug. 12, 2022), <https://arstechnica.com/gadgets/2022/08/epsons-bricked-printers-highlight-the-industrys-reparability-problem>.

²⁴ Elizabeth Chamberlain, *How Nikon Is Killing Camera Repair*, iFixit (Feb. 14, 2012), www.ifixit.com/News/1349/how-nikon-is-killing-camera-repair.

²⁵ Jason Koebler, *Do You Know Anything about Apple's "Authorized Service Provider" Program?*, Vice (Mar. 16, 2017), www.vice.com/en_us/article/ypkqwx/do-you-know-anything-about-apples-authorized-service-provider-program.

²⁶ Nick Statt, *Apple and Amazon Cut a Deal that Upended the Mac Resale Market*, Verge, (May 21, 2019), www.theverge.com/2019/5/21/18624846/amazon-marketplace-apple-deal-iphones-mac-third-party-sellers-john-bumstead.

²⁷ Michael Kan, *Google Ad Policy Change Leaves Third-Party Repair Industry in a Lurch*, PC (Aug. 8, 2019), www.pcmag.com/news/google-ad-policy-change-leaves-third-party-repair-industry-in-a-lurch.

As discussed in more detail below, IP law offers another set of tools that manufacturers can rely on to discourage and control repair. Those efforts run counter to a long history of legal skepticism towards post-sale restrictions on repair.

The Legal Basis for the Right to Repair

As a legal principle, the right to repair is firmly rooted in half a millennium of common law property doctrine and has been explicitly recognized under U.S. intellectual property law since the mid-nineteen century. The law is generally hostile to post-sale restrictions, including limitations on repair. For centuries, that has been true as a matter of both personal property and intellectual property law. This hostility grows out of deep concerns over the alienability of goods in the stream of commerce and respect for owners' autonomy to use the products they purchase as they see fit.

As early as the 15th century, English property law recognized that once an owner of “a horse, or of any other chattel” sells that item, “his whole interest ... is out of him.”²⁸ Having transferred personal property rights to the buyer, conditions on the alienation of that property are void as “against Trade and Traffique.”²⁹ Following that tradition, courts in the United States have resisted downstream restrictions on personal property on the grounds that “they offend against the ordinary and usual freedom of traffic in chattels.”³⁰ Such restraints are inconsistent with “the essential incidents of a right of general property in movables, and . . . obnoxious to public policy, which is best subserved by great freedom of traffic in such things as pass from hand to hand.”³¹ This rejection of efforts to impose post-sale restrictions on personal property has not been limited to restrictions on alienation. More broadly, courts spurned servitudes on personal property that would have allowed a seller to restrict the post-sale use of the goods in question.³² Such restrictions create a host of problems at odds with an efficient market. They typically lack sufficient notice to both present and future buyers, limit the valuable uses to which scarce resources can be put, and impose significant information costs on those who come into contact with potentially restricted goods.³³

This aversion to post-sale restrictions extends to attempts to impose limitations through assertions of IP rights as well. Although copyright, patent, and trademark law constrain the use of personal property to some extent, they nonetheless incorporate a core skepticism with respect to post-sale restrictions that interfere with downstream alienation and use. The principle of

²⁸ Edward Coke, *Institutes of the Laws of England* § 360, p. 223 (1628). Coke drew on the work of the 15th century writer, Littleton. See Charles M. Gray, *Two Contributions to Coke Studies*, 72 U. Chi. L. Rev. 1127, 1135 (2005).

²⁹ Coke, *supra* note 1 at §360.

³⁰ John D. Park & Sons Co. v. Hartman, 153 F. 24, 39 (6th Cir. 1907).

³¹ *Id.*

³² Zechariah Chafee, Jr., *The Music Goes Round and Round: Equitable Servitudes and Chattels*, 69 Harvard L. Rev. 1250, 1261 (1956); Thomas W. Merrill & Henry E. Smith, *Optimal Standardization in the Law of Property: The Numerus Clausus Principle*, 110 Yale L.J. 1, 8 (2000); Molly Shaffer Van Houweling, *The New Servitudes*, 96 Geo. L.J. 885, 897–8 (2008).

³³ *Id.*

exhaustion holds that when an embodiment of a work protected by some intellectual property right passes from the rights holder to a consumer, the rights holder's power over that particular embodiment is diminished.³⁴ As the Supreme Court has recognized in recent years, that principle is a direct outgrowth of the centuries-old tradition outlined above.³⁵

Under U.S. copyright law, the first sale doctrine is the best known exhaustion rule.³⁶ It provides that the owner of a lawful copy of a work is free to sell or otherwise dispose of that copy as they see fit, regardless of the objections of the copyright holder.³⁷ The first sale doctrine is the legal basis for public libraries, used record stores, and other secondary markets for copyrighted goods. Courts have long understood it to be copyright law's reflection of the common law aversion to impeding the free flow of goods.³⁸ In its most recent first sale case, the Supreme Court held that goods were subject to the rule regardless of where they were first manufactured.³⁹ That case directly concerned the importation of text books for sale in the United States, but the Court recognized the stakes for other products, including automobiles and consumer electronics:

Technology companies tell us that “automobiles, microwaves, calculators, mobile phones, tablets, and personal computers” contain copyrightable software programs or packaging. Many of these items are made abroad with the American copyright holder's permission and then sold and imported (with that permission) to the United States. A geographical interpretation [of § 109 of the Copyright Act] would prevent the resale of, say, a car, without the permission of the holder of each copyright on each piece of copyrighted automobile software.... Without that permission a foreign car owner could not sell his or her used car.⁴⁰

For well over a century U.S. copyright law has acknowledged a right to repair as an outgrowth of the exhaustion principle. In 1901, the American Book Company sued George

³⁴ Aaron Perzanowski & Jason Schultz, *Reconciling Personal and Intellectual Property*, 90 Notre Dame L. Rev. 1211 (2015).

³⁵ *Kirtsaeng v. John Wiley & Sons, Inc.*, 568 U.S. 519, 538–39 (2013) (“The ‘first sale’ doctrine is a common-law doctrine with an impeccable historic pedigree.”); *Impression Prod., Inc. v. Lexmark Int'l, Inc.*, 137 S. Ct. 1523, 1526, 198 L. Ed. 2d 1 (2017) (“The exhaustion rule marks the point where patent rights yield to the common law principle against restraints on alienation.”).

³⁶ Copyright law's recognition of the rights of owners is not limited to the first sale doctrine. It also permits owners to publicly display the copies they own without copyright holder permission, an essential limitation for museums. 17 U.S.C. § 109(c). And section 117 of the Copyright Act allows owners of copies of software to reproduce them as necessary to run the software and for archival purposes, to adapt them to run in new software or hardware environments, and to transfer copies of the software they purchase so long as they delete the copies in their possession. *Id.* § 117.

³⁷ 17 U.S.C. § 109(a).

³⁸ *Sebastian Int'l, Inc. v. Consumer Contacts (PTY) Ltd.*, 847 F.2d 1093, 1096 (3d Cir. 1988); *Burke & Van Heusen, Inc. v. Arrow Drug, Inc.*, 233 F. Supp. 881, 883–84 (E.D. Pa. 1964)

³⁹ *Kirtsaeng*, 568 U.S. 519.

⁴⁰ *Id.* at 542 (internal citations omitted).

Doan, a used bookseller.⁴¹ Doan acquired “soiled and torn” used children’s books, some with damaged or missing covers.⁴² To prepare them for resale, Doan repaired the books, in some cases reproducing missing covers “in exact similitude” of the originals.⁴³ The American Book Company alleged copyright infringement, but the Court of Appeals for the Seventh Circuit rejected the claim. As the owner of the books, Doan enjoyed a “right of repair or renewal” that allowed him to replace missing components and fashion new ones, even if they were “exact imitation[s] of the original.”⁴⁴ According to the court, the “right of ownership in the book carries with it and includes the right to maintain the book as nearly as possible in its original condition.”⁴⁵ To deny that right would have been “intolerable and odious.”⁴⁶ The right to repair, in short, is an inherent feature of ownership.

Nearly a century later, Congress acknowledged repair as a right owners enjoy regardless of copyright restrictions when it rejected the outcome of a case decided by the Ninth Circuit. In that case, MAI Systems, a company that made computers and software, successfully sued Peak, an independent service provider that repaired MAI devices, for copyright infringement.⁴⁷ The court agreed with MAI that by merely powering up one of its machines, Peak created unlawful copies of MAI’s software in the device’s random access memory (RAM).⁴⁸ In response to this flawed holding, Congress enacted § 117(c) of the Copyright Act, which explicitly permits owners or lessees of machines to make—or to authorize providers to make—copies of computer programs in the course of maintenance or repair.⁴⁹ Since then, the U.S. Copyright Office has repeatedly concluded that diagnosis, repair, and maintenance activities are “generally noninfringing.”⁵⁰

Patent law has its own long history of embracing repair as an inherent right of owners of patented devices. Under the patent exhaustion doctrine, the sale of a patented article ends the patentee’s control over its sale, use, or repair. This fundamental limitation on the scope of a patentee’s rights dates back to the mid-1800s. As the Court then understood, “when the machine passes to the hands of the purchaser, it is no longer within the limits of the monopoly. It passes

⁴¹ Doan v. American Book Co., 105 F. 772 (7th Cir. 1901).

⁴² Id. at 777.

⁴³ Id. at 778.

⁴⁴ Id. at 776.

⁴⁵ Id. at 777.

⁴⁶ Id.; *see also* Bureau of National Literature v. Sells, 211 F. 379, 380 (W.D. Wash. 1914).

⁴⁷ MAI Sys. Corp. v. Peak Computer Inc., 991 F.2d 511 (9th Cir. 1993).

⁴⁸ The Ninth Circuit tersely concluded in a footnote that “[s]ince MAI licensed its software, the Peak customers do not qualify as ‘owners’ of the software.” Id. at 519, n5. *But see* Cartoon Network v. CSC Holdings, Inc., 536 F.3d 121, 130 (2d Cir. 2008) (holding temporary buffer copies are not “copies” under the Copyright Act).

⁴⁹ 17 U.S.C. § 117(c).

⁵⁰ Register of Copyrights, *Section 1201 Rulemaking: Eight Triennial Proceeding to Determine Exemptions to the Prohibition on Circumvention, Recommendation of the Register of Copyrights* (2021) (noting that “diagnosis, maintenance, and repair of software-enabled consumer devices are likely to be fair uses where the purpose is to restore device functionality”); U.S. Copyright Office, *Software-Enabled Consumer Products* 35 (2016) (“Properly construed, section 117 should adequately protect most repair and maintenance activities”).

outside of it, and is no longer under the protection of the act of Congress . . . [and] becomes [the owner's] private, individual property.”⁵¹ Just a few years ago, the Court reaffirmed in *Impression Products v. Lexmark* that “once a patentee sells an item ... the patent laws provide no basis for restraining the use and enjoyment of the product. Allowing further restrictions would run afoul of the ‘common law’s refusal to permit restraints on the alienation of chattels.”⁵² To illustrate the practical importance of that rule, the Court turned to an example drawn from the auto repair industry:

Take a shop that restores and sells used cars. The business works because the shop can rest assured that, so long as those bringing in the cars own them, the shop is free to repair and resell those vehicles. That smooth flow of commerce would sputter if companies that make the thousands of parts that go into a vehicle could keep their patent rights after the first sale. Those companies might, for instance, restrict resale rights and sue the shop owner for patent infringement. And even if they refrained from imposing such restrictions, the very threat of patent liability would force the shop to invest in efforts to protect itself from hidden lawsuits. Either way, extending the patent rights beyond the first sale would clog the channels of commerce, with little benefit from the extra control that the patentees retain.⁵³

As early as 1850, the Court recognized that repair of a patented machine was a legally privileged act of “restoration” that reflected “no more than the exercise of that right of care which everyone may use to give duration to that which he owns.”⁵⁴ A century later, the Court underscored this principle when it held that the replacement of the fabric cover of a convertible car roof was lawful as a matter of patent exhaustion.⁵⁵ As the Court explained, the “mere replacement of individual unpatented parts, one at a time, whether of the same part repeatedly or different parts successively, is no more than the lawful right of the owner to repair his property.”⁵⁶

Like copyright and patent law, trademark law also recognizes the principle of exhaustion and facilitates the repair of goods. Once a product bearing a trademark is sold, the mark owner’s ability to control post-sale use and transfer is severely limited.⁵⁷ Not only can the owner of a trademarked good resell it, they can repair it. In a case brought by Champion in 1947, the Supreme Court held that so long as reconditioned spark plugs were accurately labeled as “repaired,” the reseller had no obligation to remove the Champion mark.⁵⁸ More recently, courts

⁵¹ *Bloomer v. McQuewan*, 55 U.S. (14 How.) 539 (1852).

⁵² *Impression Prod., Inc. v. Lexmark Int’l, Inc.*, 137 S. Ct. 1523 (quoting *Kirtsaeng*, 568 U.S. at 538)

⁵³ *Id.* at 1532.

⁵⁴ *Wilson v. Simpson*, 50 U.S. 109 (1850).

⁵⁵ *Aro Mfg. Co., Inc. v. Convertible Top Co.*, 365 US 336 (1961).

⁵⁶ *Id.* at 346.

⁵⁷ *Sebastian Int’l, Inc. v. Longs Drug Stores Corp.*, 53 F.3d 1073, 1074 (9th Cir. 1995) (the right “to control distribution of its trademarked product does not extend beyond the first sale of the product”).

⁵⁸ *Champion Spark Plug Co. v. Sanders*, 331 U.S. 125 (1947).

have endorsed the right of refurbishers to reapply trademarked logos to products before reselling them, on the condition that they were properly labeled.⁵⁹

Taken together, these longstanding legal rules support the notion that a right to repair one's personal property is an inherent incident of ownership. These doctrines have helped secure the rights of property owners to repair the things they own as they see fit, free from restrictions imposed by manufacturers and retailers. But as discussed below, current interpretations and applications of IP law can nonetheless interfere with repair, in a marked departure from these established principles.

Copyright & Repair

Copyright law implicates the right to repair in two primary ways. First, manufacturers have repeatedly attempted to leverage copyright as a tool to control information about replacement parts and repair procedures. Second, the software necessary to operate, diagnose, and repair devices is often protected by copyright law, allowing manufacturers to claim that bypassing digital locks that restrict access to this code for repair purposes is unlawful. These claims are based on over-broad interpretations of copyright law. When given the opportunity to evaluate those claims, courts and the Copyright Office have repeatedly rejected them.

Part Numbers & Manuals

Beginning in the 1980s, manufacturers began asserting copyright in numbering systems for replacement parts in an effort to steer consumers away from third-party parts. Facing competition from independent part manufacturers, lawn care equipment maker Toro sued R&R Products, alleging it had unlawfully copied Toro's part numbering system. R&R marketed its products in a mail-order catalog that listed Toro's part name and number alongside R & R's replacement part and price. The court rejected Toro's copyright assertion because its system of arbitrarily assigning a random number to each replacement part failed to satisfy copyright's minimal standard for creativity.⁶⁰

Likewise, the court rejected ATC's copyright claims based on its parts catalog, which featured illustrations of disassembled vehicle transmissions. Each image showed the various parts, their physical relationship within the assembly, and their part numbers. When a new competitor, Whatever It Takes, launched a similar catalog with the same part numbers, ATC sued.⁶¹ ATC argued that its numbering system, entailed judgment and creativity. Nonetheless, the court held that the system was unprotectable since ATC's taxonomy left it little discretion as to the number of any individual part. Moreover, the court rejected ATC's claim that Whatever It Takes copied its illustrations. Since those drawings "were intended to be as accurate as possible" they were "the antithesis of originality."

More recently, manufacturers have taken a new tack. Rather than part numbers, they've claimed copyright in repair manuals. These documents contain useful information for diagnosing and repairing various common failures. They might provide step-by-step instructions for

⁵⁹ Nitro Leisure Prod., L.L.C. v. Acushnet Co., 341 F.3d 1356, 1357 (Fed. Cir. 2003).

⁶⁰ Toro Co. v. R & R Prod. Co., 787 F.2d 1208, 1213 (8th Cir. 1986).

⁶¹ ATC Distribution Grp., Inc. v. Whatever It Takes Transmissions & Parts, Inc., 402 F.3d 700, 703 (6th Cir. 2005). *See also* Southco, Inc. v. Kanebridge Corp., 258 F.3d 148 (3d Cir. 2001).

disassembling a device or replacing broken components, saving consumers time, money, and frustration. In many instances, manuals help decipher otherwise inscrutable error codes necessary to diagnose and repair electronics, home appliances, vehicles, and medical equipment.

In 2012, Toshiba demanded the removal of repair manuals for hundreds of laptop models from a free website,⁶² citing the copyright in its manuals. By reproducing and displaying them online, the company argued, Hicks was infringing its exclusive rights. And in 2020, iFixit announced its Medical Device Repair Database, a collection of repair manuals for more than 13,000 ventilators, anesthesia systems, and respiratory analyzers, among other devices.⁶³ A number of manufacturers, including Steris, an Ohio-based manufacturer of medical sterilization equipment, have sent demands to iFixit to remove these materials.⁶⁴ But there are good reasons to doubt that a court would side with these efforts to restrict access to repair information.

First, most of the content of repair manuals is simply not subject to copyright.⁶⁵ Part names and numbers, as well as simple illustrations are beyond the scope of copyright protection. Likewise, the methods and processes of repair and diagnosis contained in manuals cannot be protected by copyright law.⁶⁶ Even if assuming step-by-step, mechanical descriptions of uncopyrightable processes meet copyright's originality requirement, they would almost certainly fall within the merger doctrine, a principle that recognizes some ideas can only be expressed in a handful of ways. Aside from minor variations in word choice, any clear, accurate description of such a process would be nearly identical to the formulation contained in a manual. Under those circumstances, the idea and its expression are considered merged, and neither is subject to copyright.⁶⁷

That barrier aside, the reproduction and distribution of manuals would likely constitute a fair use. Among the key factors courts consider in fair use cases is "the purpose and character of the use."⁶⁸ That's particularly true when manuals are made available for free to facilitate repair. A website that collects and organizes hundreds of manuals in a single location would also likely be engaged in a transformative use by creating an information location tool. In addition, the factual nature of the copyrighted works at issue would favor a fair use determination. And to the extent a copyright holder can identify any market harm from the distribution of manuals, that harm is not

⁶² *Tim's Laptop Service Manuals*, Future Proof, www.tim.id.au/blog/tims-laptop-service-manuals/#toc-toshiba; Mike Masnick, *Toshiba: You Can't Have Repair Manuals Because They're Copyrighted And You're Too Dumb To Fix A Computer*, Techdirt, 12 November 2012, www.techdirt.com/articles/20121110/22403121007/toshiba-you-cant-have-repair-manuals-because-theyre-copyrighted-youre-too-dumb-to-fix-computer.shtml.

⁶³ Kyle Wiens, *Introducing the World's Largest Medical Repair Database, Free for Everyone*, iFixit, 19 May 2020, www.ifixit.com/News/41440/introducing-the-worlds-largest-medical-repair-database-free-for-everyone.

⁶⁴ *Letter from Steris to iFixit 5-16-2020*, Electronic Frontier Foundation, www.eff.org/document/letter-steris-ifixit-5-16-2020.

⁶⁵ *Maintenance Manual: Harmony LA Surgical Lighting and Visualization System*, iFixit, www.ifixit.com/Document/IDkC64cS1RNYhqYc/Steris+Harmony+LA+Surgical+Lighting+Maintenance+Manual.pdf.

⁶⁶ 17 U.S.C. § 102(b).

⁶⁷ *Morrissey v. Proctor & Gamble Co.*, 379 F.2d 675 (1st Cir. 1967).

⁶⁸ 17 U.S.C. § 107.

attributable to the value of the manuals' creative expression, but instead is traceable to the unprotected facts, methods, and processes they contain. Indeed, when Gulfstream sued a firm that copied and distributed its aircraft manuals, the court determined that "granting copyright protection under these facts would not serve the purposes of copyright law" and concluded that "as a matter of law that [the defendant] has made a fair use of Gulfstream's manuals."⁶⁹

Circumvention & Software Tools

Software introduces another avenue for manufacturers to enlist copyright law to limit repair. Software code is essential to the functioning, diagnosis, and repair of both modern consumer goods and industrial equipment. Often, manufacturers restrict access to that software code using technological protection measures, or what is more commonly known as digital rights management (DRM) technology.

In 1998, Congress enacted the Digital Millennium Copyright Act (DMCA). Section 1201 of the DMCA makes it unlawful to circumvent technological protection measures that restrict access to copyrighted works, including software.⁷⁰ In other words, it is illegal to remove or bypass digital locks meant to restrict access to or copying of copyrighted material, including software. In addition, § 1201 prohibits the manufacture, sale, or distribution of technological tools meant to facilitate or enable acts of circumvention.⁷¹ These provisions were intended to encourage traditional copyright holders—like movie studios, record labels, and book publishers—to make their works available online.⁷² By providing some additional layers of legal protection for DRM, the law was designed to allay the reasonable fears of copyright holders, who worried that digital distribution would expose them to widespread infringement.

Despite these goals, manufacturers of printers, garage door openers, and other devices quickly realized that § 1201 offered them the chance to limit competition for aftermarket parts and service. Courts rebuffed those early efforts to expand the DMCA's scope.⁷³ But the risk of broad applications of § 1201 remains a concern for repair providers and part makers. Today, manufacturers continue to rely on digital locks to restrict access to the embedded code that controls devices from smartphones to cars. Because that code is often necessary for diagnosis and repair, those protection measures pose practical hurdles for consumers and repair providers. Section 1201 compounds those difficulties by introducing legal liability for removing or bypassing the locks on the devices.

One court rightly rejected an attempt to use § 1201 to shut down a repair provider.⁷⁴ StorageTek sold data storage systems. Those systems were made up of a number of "silos," each containing a robot arm that inserted tape cartridges into various drives. Each silo was operated by

⁶⁹ Gulfstream Aerospace v. Camp Systems Intern, 428 F. Supp. 2d 1369, 1381 (S.D. Ga. 2006).

⁷⁰ 17 U.S.C. § 1201.

⁷¹ Id.

⁷² Brian T. Yeh, *The Digital Millennium Copyright Act: Exemptions to the Prohibitions to the Prohibition of Circumvention*, Congressional Research Service (2008).

⁷³ Chamberlain Group, Inc. v. Skylink Technologies, Inc., 381 F.3d 1178 (Fed. Cir. 2004), Lexmark International, Inc. v. Static Control Components, Inc., 387 F.3d 522 (6th Cir. 2004).

⁷⁴ Storage Tech. Corp. v. Custom Hardware Eng'g & Consulting, Inc., 421 F.3d 1307 (Fed. Cir. 2005)

a control unit, and collectively the system was controlled by a networked management unit. Those units ran StorageTek's software, including diagnostic programs, which it claimed to license to system owners. StorageTek sued Custom Hardware Engineering & Consulting (CHE), a competing repair provider, alleging that CHE circumvented StorageTek's protection measures to access its software code in the process of repairing customers' equipment. StorageTek's software generated error codes, which CHE needed to capture in order to diagnose faulty machines. To access those codes, CHE had to override GetKey, a password protection scheme StorageTek created to lockdown its systems. At first, CHE used a tool that generated multiple passwords to crack GetKey through brute force. Later, CHE learned how to mimic the signals sent to the control unit to divulge error codes. StorageTek alleged that both techniques circumvented its access controls.

The Federal Circuit was not persuaded. In a prior case, the court held that to violate § 1201, circumvention must have some plausible connection to an act of copyright infringement.⁷⁵ Without that "critical nexus," circumvention is perfectly lawful. Applying the same logic to StorageTek's claim, the court was satisfied that there was little chance circumvention would lead to infringement since CHE was entitled to make copies of the software under § 117 of the Copyright Act. While that reasoning would seem to protect owners and repair providers from circumvention liability in many circumstances, other courts have declined to adopt the Federal Circuit's nexus requirement, opening repair providers up to potential liability.⁷⁶

When it enacted § 1201, Congress recognized its potential for unintended consequences. So it called on the Copyright Office and the Librarian of Congress to conduct a rulemaking every three years to identify noninfringing uses that are likely to be adversely affected by the anticircumvention provision. Those uses are then protected by temporary exemptions.⁷⁷ In 2015, the Librarian adopted an exemption permitting the circumvention of DRM that restricts access to software that controls "motorized land vehicles" for the purpose of diagnosis and repair.⁷⁸ In the next rulemaking, that exemption was expanded to include software that controls a "smartphone or home appliance or home system, such as a refrigerator, thermostat, HVAC or electrical system."⁷⁹ In 2021, the repair exemption was expanded again to include software-enabled consumer devices, video game consoles, and medical devices. Echoing its earlier conclusions in the Software-Enabled Consumer Products study,⁸⁰ the Copyright Office concluded that the use of software for diagnosis and repair was likely a fair use and/or protected under the repair provisions of § 117.⁸¹

⁷⁵ Chamberlain, 381 F.3d 1178.

⁷⁶ MDY Industries, LLC v. Blizzard Entertainment, Inc., 629 F.3d 928 (9th Cir. 2010).

⁷⁷ 17 U.S.C. § 1201(a)(1)(C).

⁷⁸ Exemption to Prohibition on Circumvention of Copyright Protection Systems for Access Control Technologies, 80 Fed. Reg. 208, 65954 (October 28, 2015).

⁷⁹ Exemption to Prohibition on Circumvention of Copyright Protection Systems for Access Control Technologies, 83 Fed. Reg. 208, 54023 (October 26, 2018).

⁸⁰ U.S. Copyright Office, Software-Enabled Consumer Products (2016), <https://www.copyright.gov/policy/software/software-full-report.pdf>.

⁸¹ Exemption to Prohibition on Circumvention of Copyright Protection Systems for Access Control Technologies, 86 Fed. Reg. 206, 59627 (October 28, 2021).

These exemptions were important vindications of the legality of circumvention for repair purposes, but they are severely limited in their practical effect. The Copyright Office’s rulemaking authority and the resulting exemptions only extend to § 1201’s anticircumvention provision. They offer no defense to the prohibition on trafficking in circumvention tools.⁸² So while it is lawful to circumvent in order to repair, creating and sharing tools that enable circumvention are not. This creates a deep mismatch between the legal rights consumers theoretically enjoy under the law—the right to circumvent in order to engage in repair—and their practical ability to exercise those rights. Even sophisticated users of technology do not have the necessary expertise to code their own circumvention tools from scratch. Indeed, even creating a tool for one’s own use to take advantage of an exemption may still violate the antitrafficking provision, as the Copyright Office has noted. Without the ability to access circumvention tools tailored for repair, the beneficiaries of these exemptions are left with a hollow legal right and no legal remedy.⁸³

Congress could address this state of affairs by enacting permanent statutory exceptions to both the anticircumvention and antitrafficking provisions of § 1201 for the purposes of diagnosis and repair. The Freedom to Repair Act Act (H.R. 6566), introduced in the 117th Congress, would have done just that. Without this needed statutory reform, non-infringing acts of repair will remain out of reach to consumers.

Design Patents & Repair

Design patents present another set of challenges for repair. Unlike utility patents, which grant exclusive rights to inventors of useful innovations, design patents are meant to grant rights in the aesthetic contributions of a designer. In other words, they apply to the ornamental appearance of a design, not its functionality. Design patents extend to “any new, original, and ornamental design for an article of manufacture.”⁸⁴ Under the statute, patentable designs must be novel, nonobvious, and ornamental.⁸⁵ They include the surface ornamentation of an article, including colors and graphic elements, its three-dimensional configuration or shape, or any combination of the above.⁸⁶

Once granted, design patents last for fifteen years. During that period, the patent holder has the legal right to prevent others from making, using, selling, offering to sell, or importing the patented design.⁸⁷ To prove infringement, the patentee must show that “an ordinary observer, taking into account the prior art, would believe the [defendant’s] design to be the same as the patented design.”⁸⁸ In other words, anyone who makes, sells, or even uses a product that looks too much like a patented design without permission infringes.

⁸² 17 U.S.C. § 1201.

⁸³ U.S. Copyright Office, Section 1201 of Title 17 (2017), <https://www.copyright.gov/policy/1201/section-1201-full-report.pdf>.

⁸⁴ 35 U.S.C. § 171(a)

⁸⁵ Id. § 171(a) & (b).

⁸⁶ Sarah Burstein, *The “Article of Manufacture” in 1887*, 32 Berkeley Tech. L.J. 1 (2017) (hereinafter *1887*).

⁸⁷ 35 U.S.C. § 271(a).

⁸⁸ *Egyptian Goddess, Inc. v. Swisa, Inc.*, 543 F.3d 665, 682 (Fed. Cir. 2008).

Over time, shifts in judicial interpretation have eroded safeguards that limited the availability and reach of design patents. That liberalization led to a massive increase in the number of patented designs. In 1980, the PTO granted around three thousand design patents.⁸⁹ In 2019, it handed out nearly 35,000, more than a tenfold increase.⁹⁰ And a 2010 study revealed that the Patent Office rejected less than 2% of design patent applications on substantive grounds.⁹¹ Meanwhile, damages in design patent cases have reached new highs. After Apple sued Samsung for infringing its iPhone design patents—including its rounded corners, home button, and grid of app icons—a jury awarded more \$500 million in damages.⁹²

These developments have dire consequences for repair. If design patents on components and replacement parts are easy to secure, manufacturers have the power to deny those parts to owners and repair providers, to charge unreasonably high prices, or to condition access to parts on other onerous terms.

A recent case decided by the Federal Circuit illustrates the worry. The Automotive Body Parts Association (ABPA) sued to invalidate two Ford design patents on a truck hood and head lamp.⁹³ ABPA argued that since consumers prefer parts that not only serve the same function as the original, but also restore their vehicles' appearance, those designs should be deemed functional rather than ornamental. The Federal Circuit disagreed, holding that "the aesthetic appeal of a design to consumers is inadequate to render that design functional."⁹⁴ The court also rejected ABPA's exhaustion and repair arguments. Although the sale of a vehicle exhausts Ford's control over the physical components that make it up, it does not give the owner the right to use unauthorized parts that copy a patented design. And since Ford's design patents covered individual parts rather than the vehicle as a whole, patent law's right of repair didn't permit making or using unauthorized parts.

The aftermarket for vehicle parts and accessories amounts to hundreds of billions of dollars each year in the United States alone.⁹⁵ Historically, that market has been competitive, allowing owners to choose between original manufacturer parts or a variety of less expensive non-original equipment manufacturer (OEM) options, saving roughly \$1.5 billion a year when it comes to collision repairs.⁹⁶ But design patents threaten to undermine that competitive landscape, forcing consumers and repair shops to purchase original parts at inflated prices.

⁸⁹ U.S. Patent Statistics Chart Calendar Years 1963 - 2019, U.S. Patent and Trademark Office, www.uspto.gov/web/offices/ac/ido/oeip/taf/us_stat.htm.

⁹⁰ *Id.*

⁹¹ Dennis David Crouch, *A Trademark Justification for Design Patent Rights* (Univ. of Mo. Sch. of Law Legal Studies, Research Paper No. 2010-17, 2010), ssrn.com/abstract=1656590.

⁹² Reuters, *Jury Awards Apple \$539 Million in Samsung Patent Case*, New York Times, 24 May 2018, www.nytimes.com/2018/05/24/business/apple-samsung-patent-trial.html.

⁹³ *Auto. Body Parts Ass'n v. Ford Glob. Techs., LLC*, 930 F.3d 1314 (Fed. Cir. 2019).

⁹⁴ *Id.*

⁹⁵ *Total U.S. Aftermarket Forecast to Decline 8.8% But Expected to Rebound in 2021*, Autocare Association, www.autocare.org/total_us_aftermarket_forecast_decline_but_expected_rebound_2021.

⁹⁶ Joshua D. Sarnoff, *White Paper on Protecting the Consumer Patent Law Right of Repair and the Aftermarket for Exterior Motor Vehicle Repair Parts: The Parts Act, S. 812; H.R. 1879, 115th Congress* (2017), ssrn.com/abstract=3082289 or dx.doi.org/10.2139/ssrn.3082289.

Since 2005, manufacturers have increasingly turned to design patents to target competitive repair parts. That trend began when Ford filed a complaint with the International Trade Commission that stopped imports of replacement parts for its F-150 pickup trucks. The company then struck a deal giving its one-time competitor the exclusive right to distribute aftermarket Ford parts.⁹⁷ In the wake of Ford's strategy, other carmakers have used design patents on bumpers, fenders, headlights, and other parts to threaten manufacturers, importers, and distributors of non-OEM parts, and the repair shops that use them.⁹⁸

This same strategy can just as easily be exploited by the makers of other devices. Replacement parts for home appliances, consumer electronics, smartphones and other devices are covered by design patents and have led to litigation against third-party competitors.⁹⁹ Apple has even obtained a design patent on the glass assembly of an iPhone screen, a move that could imperil any third party replacement parts for this ubiquitous piece of technology, as the image below illustrates.¹⁰⁰

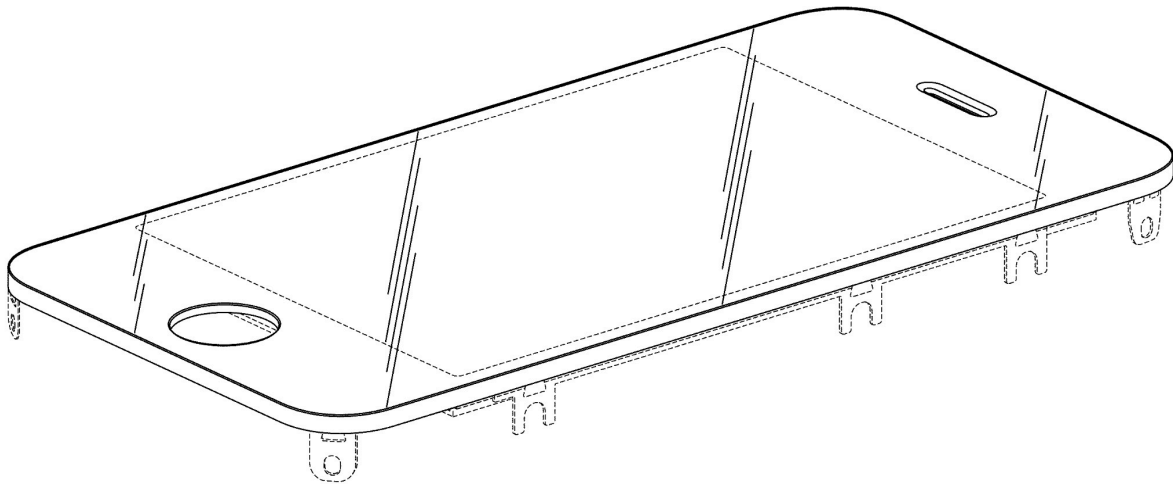

Two overlapping sets of changes in the judicial interpretation of design patent law explain the current state of affairs. First, courts have expanded the subject matter of patentable designs far beyond what Congress intended. Second, the USPTO, following the clear directives of the Federal Circuit, has all but eliminated any meaningful barrier to obtaining design patents. In effect, this liberalization of design patent law has given manufacturers a cheap and easy way to target competitors without clearing the much higher hurdles of the utility patent regime.

⁹⁷ Id.

⁹⁸ Id.

⁹⁹ Complaint, *KX Technologies v. Dilmen* (D. Ct.) (3:16-cv-00745) (replacement water filter); Complaint, *Electrolux Home Prods. v. National Trade Supply* (W.D N.C.) (3:21-cv-246) (replacement water filter); Complaint, *Makita v. Kastar* (C.D. Cal.) (2:17-cv-01537) (replaceable battery); *Thermo King Corporation v. A.G.A. Distribution Specialists* (D. Minn.) (0:22-cv-00276) (replacement grill for refrigerator).

¹⁰⁰ U.S. Patent No. D703,633S (issued Apr. 29, 2014).

Under the terms of the Patent Act, patents are available for the “design for an article of manufacture.”¹⁰¹ The interpretation of that phrase is central to understanding the proper scope of design patent subject matter. By interpreting it broadly, courts have opened the door to design patents on products, like complex machines, that were never intended. What’s more, courts have paved the way for design patents that claim only parts—and fragments of those parts—of a product.

When the U.S. Supreme Court heard an appeal in Apple’s lawsuit against Samsung, it defined “article of manufacture” broadly. According to the Court, that term “encompasses both a product sold to a consumer and a component of that product” because it means “simply a thing made by hand or machine.”¹⁰² But that reading misunderstands the plain meaning and long history of the term. As Sarah Burstein, one of the leading scholars of the U.S. design patent regime, has argued, the phrase “article of manufacture” refers “to a tangible item made by humans—other than a machine or composition of matter—that had a unitary structure and was complete in itself for use or for sale.”¹⁰³

As an initial matter, “machines” were long understood as outside the scope of design patentable subject matter. Unlike utility patents, which extend to any “process, machine, manufacture, or composition of matter,” design patents are available only for “articles of manufacture.”¹⁰⁴ “Machines” are conspicuously excluded. For decades, the Patent Office understood that machines were not considered articles of manufacture and were ineligible for design patents.¹⁰⁵ The first patent claiming the design of a machine wasn’t granted until nearly a century after the design patent regime was created.¹⁰⁶ In the decades since, the Patent Office has routinely granted and the courts have erroneously enforced design patents on machines.

Even if we set aside this error, design patent law took another, more recent wrong turn. Longstanding principles of design patent law focused attention on the design as a whole, not its constituent parts. Consumers don’t perceive a design as a collection of lines, shapes, and colors, but as an integrated, unitary whole. As one court put it in 1900, “The essence of a design resides, not in the elements individually, nor in their method of arrangement, but in the tout ensemble—in that indefinable whole that awakens some sensation in the observer’s mind.”¹⁰⁷ Understandably then, design patent applicants claiming some fragment of an article were typically met with hostility. An application claiming the design of the “forward corner of an automobile body,” for example, was rejected because it did not “cover a complete article of manufacture.”¹⁰⁸

¹⁰¹ 35 U.S.C. § 171.

¹⁰² *Samsung Electronics Co. v. Apple Inc.*, 580 U.S. 53 (2016).

¹⁰³ Burstein, 1887.

¹⁰⁴ 35 U.S.C. §§ 101 & 171.

¹⁰⁵ Burstein, 1887; *Ex parte Adams*, 1898 Dec. Comm’r Pat. 115; *Ex parte Steck*, 1902 Dec. Comm’r Pat. 9.

¹⁰⁶ *In re Koehring*, 37 F.2d 421 (CCPA 1930).

¹⁰⁷ *Pelouze Scale & Mfg. Co. v. Am. Cutlery Co.*, 102 F. 916, 918 (7th Cir. 1900); *see also Gorham Co. v. White*, 81 U.S. 511 (1871); Sarah Burstein, *How Design Patent Law Lost Its Shape*, 41 *Cardozo L. Rev.* 555, 594 (2019) (hereinafter *Lost Shape*).

¹⁰⁸ *Ex parte Northup*, 24 USPQ 63 (Pat. Off. Bd. App. 1932).

It wasn't until 1980 that courts explicitly embraced claims identifying a mere fragment of an article of manufacture. In *Zahn*, the U.S. Court of Customs and Patent Appeals (CCPA)—the predecessor of today's Federal Circuit—considered an application for an “ornamental design for a Shank of a Drill Bit.”¹⁰⁹ The claimed design was limited to the upper portion of the bit and explicitly disclaimed the cutting edge—the part that bores the hole. In keeping with its accepted practice, the PTO rejected the application. But on appeal, the CCPA disagreed. According to the court, the fact that the application claimed only a portion of the drill bit was no barrier to patentability. Specifically, the court held that “a design for an article of manufacture may be embodied in less than all of an article of manufacture.”¹¹⁰ But in characterizing the issue in those terms, the court assumed that *Zahn's* partial claim constituted “a design for an article of manufacture” in the first place.¹¹¹ This begs the question. The issue the court needed to decide was whether a claim directed to a fragment of an article of manufacture is a patentable design at all. As Professor Burstein has persuasively argued, *Zahn* relies on a misreading of the Patent Act and faulty logic.¹¹²

The risks of defining of “articles of manufacture” broadly could be tempered if patent examiners assiduously scrutinized the substantive requirements for design patents. Unfortunately, that's the opposite of what's happened. The Federal Circuit, exercising its exclusive power to review the decisions of the PTO, has consistently lowered the bar for obtaining a design patent. Today, acquiring a design patent requires little more than \$5000 and a modicum of patience.¹¹³

To qualify for a patent under the terms defined by Congress, a design must be novel, nonobvious, and ornamental. But under the prevailing Federal Circuit interpretations, those requirements rarely present meaningful hurdles.¹¹⁴ To meet the novelty standard, an applicant only needs to show that its design is not “identical in all material respects” to any previously disclosed design—the “prior art,” in patent law parlance.¹¹⁵ In practice, the Federal Circuit is quick to identify minor differences between claimed designs and the prior art, highlighting minor discrepancies that would likely escape the attention of reasonably perceptive consumers, ensuring that the vast majority of designs will be treated as novel.¹¹⁶

In theory, nonobviousness is a higher barrier. Even if the precise design has never been seen before, it qualifies for a patent only if it would not have been obvious to a designer of ordinary skill in the relevant field.¹¹⁷ Here, the Federal Circuit applies a two-part test. First, it looks for a primary reference in the prior art—an existing design that is “basically the same as the claimed design.” Assuming it finds one, the court moves on to step two, where it searches for secondary reference designs that contain other elements of the claimed design. If the

¹⁰⁹ Application of *Zahn*, 617 F.2d 261 (C.C.P.A. 1980).

¹¹⁰ *Id.*

¹¹¹ Burstein, *Lost Shape*.

¹¹² *Id.*

¹¹³ Sarah Burstein, *Costly Designs*, 77 Ohio State Law Journal 107, 124 (2016) (noting \$5000 estimate); Crouch, *supra* note 91 (noting allowance rate over 90%).

¹¹⁴ Sarah Burstein, *Is Design Patent Examination Too Lax?*, 33 Berkeley Tech. L.J. 607, 608 (2018) (hereinafter *Too Lax*).

¹¹⁵ High Point Design LLC v. Buyer's Direct, Inc., 621 F. App'x 632, 638 (Fed. Cir. 2015)

¹¹⁶ *Id.* (noting minor variations in the sole and fuzzy trim on shoe designs).

¹¹⁷ MRC Innovations, Inc. v. Hunter Mfg., 747 F.3d 1326, 1331 (Fed. Cir. 2014).

combination of the primary and secondary references would be obvious to a designer of ordinary skill, the claimed design is obvious. Much like its approach to novelty, however, the Federal Circuit is keenly attuned to subtle differences between the claimed design and any would-be primary reference. And without a primary reference, a claimed design can't be deemed obvious.¹¹⁸

Finally, patented designs are supposed to be ornamental. Utilitarian innovations—that is to say, inventions that offer some new functional advantage—are meant to be protected with utility patents. The ornamentality requirement should exclude designs that contribute to a device's operation.¹¹⁹ But again, the Federal Circuit has undermined this core requirement. Unless a design is “dictated by function,” it is considered ornamental.¹²⁰ As long as some alternative design offers “the same or similar functional capabilities,” a design will be treated as ornamental.¹²¹

This anemic standard opens the door for patents on designs that are in no discernible sense ornamental, like standard door hinges and flexible exhaust pipes.¹²² Even worse, it permits design patents that offer substantial functional advantages.¹²³ Apple successfully asserted a design patent on the rounded corners of the iPhone despite the Federal Circuit's acknowledgement that they improved the device's “pocketability” and “durability.”¹²⁴ And in an earlier case, the court upheld a design patent on the shape of a multi-function demolition tool—a combination hammer and pry bar—as ornamental, despite the fact that its size and shape were inseparable from its function.¹²⁵

Even internal components have been deemed ornamental. According to the court, a design is ornamental even if it is typically hidden from view during normal use. It just needs to be seen at some point between its manufacture and ultimate destruction.¹²⁶ In one illustrative case, the Federal Circuit insisted that the design of an artificial hip, despite being hidden once implanted, could be considered ornamental since it was advertised to doctors.¹²⁷

Taken together, the expansion of design patent subject matter and the erosion of its substantive requirements allow for the proliferation of exclusive rights in the components that make up our devices. Those rights, and the threat of litigation they enable, put third party repair markets at risk. If the parts needed to repair a car, laptop, or dishwasher are patented, they are likely to cost significantly more, if they are available at all. Authorized repair partners are likely to have more reliable access to those parts, putting additional pressure on independent providers to agree to unfavorable terms to secure the blessing of the manufacturer.

¹¹⁸ Burstein, *Too Lax*, *supra* note 114.

¹¹⁹ Christopher Buccafusco, Mark A. Lemley, & Jonathan S. Masur, *Intelligent Design*, 68 *Duke Law Journal* 75 (2018).

¹²⁰ *Best Lock Corp. v. Ilco Unican Corp.*, 94 F.3d 1563, 1567 (Fed. Cir. 1996).

¹²¹ *Id.*; *Ethicon Endo-Surgery, Inc. v. Covidien, Inc.*, 796 F.3d 1312, 1329 (Fed. Cir. 2015); *see also* Burstein, *Too Lax*, *supra* note 114.

¹²² *Id.*

¹²³ Buccafusco, Lemley & Masur, *supra* note 119.

¹²⁴ *Apple Inc. v. Samsung Elecs. Co.*, 786 F.3d 983 (Fed. Cir. 2015).

¹²⁵ *Richardson v. Stanley Works, Inc.*, 597 F.3d 1288 (Fed. Cir. 2010).

¹²⁶ Burstein, *Too Lax*.

¹²⁷ *In re Webb*, 916 F.2d 1553, 1557 (Fed. Cir. 1990).

These judicial expansions of design patent law explain the source of the challenges facing repair. But solving those problems does not require a ground-up overhaul of the design patent regime, justified though it may be. The Save Money on Auto Repair Transportation (SMART) Act offers a sensible, measured solution that would help restore a competitive market for automotive collisions parts.¹²⁸ In effect, the SMART Act creates a defense to design patent infringement when collision parts are manufactured and sold for the purposes of restoring a vehicle's appearance. The defense would apply only after the part has been available on the market for 30 months. This defense does not shorten the design patent term, nor would it be available to competing automakers. If enacted, it would reduce the costs of automobile repair and reinvigorate competition in the market for collision parts.

Given the cost of collision repair, design patents on automotive parts are an appropriate starting point for these much-needed reforms. But as described above, the same tactics automakers deploy are already being used by a wide range of manufacturers of consumer devices and industrial equipment makers. I would urge the Subcommittee to consider a broader defense that would include not only automotive parts, but any design patent that covers a component part of a device when manufactured and sold for the purposes of repair.

Conclusion

The right to repair is a longstanding principle, reflected in both personal property and IP law. Without it, the fundamental notion of ownership—of our cars, our communications devices, our home appliances—is under threat. Safeguarding that right to repair is a complex legal problem that has no single solution. Beyond IP law, it presents questions of antitrust, consumer protection, and contract law, among others. Nonetheless, by addressing the ways in which IP law interferes with rights of Americans to fix the things they buy, Congress is positioned to help maintain and restore this core right of property owners.

¹²⁸ H.R. 1707 (118th Congress).